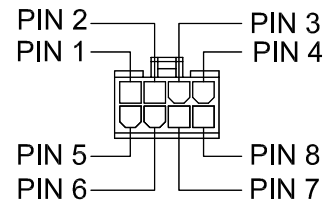

Table.1 Connector Interface (Motor)

Pin No.	COLOR	FUNCTION	LEAD WIRE
1	BLACK	GND	UL1061 AWG 26
2	BLUE	Motor W	UL 1061 AWG 22
3	GREEN	Motor V	
4	YELLOW	Motor U	
5	RED	VCC	
6	BROWN	Hall C	UL 1061 AWG 26
7	GRAY	Hall B	
8	WHITE	Hall A	

A Fig.1 Connecetor



REV.	DATE	DESCRIPTION	DRWN
MATERIAL	-	PLATING	-
SCALE	N/S	PAPER	A4
		QUANTITY	-
DWG NO.	DSM-721-24V-A-M		DIMENSION mm



SUBJECT
DSM-721
(Standard module Type)

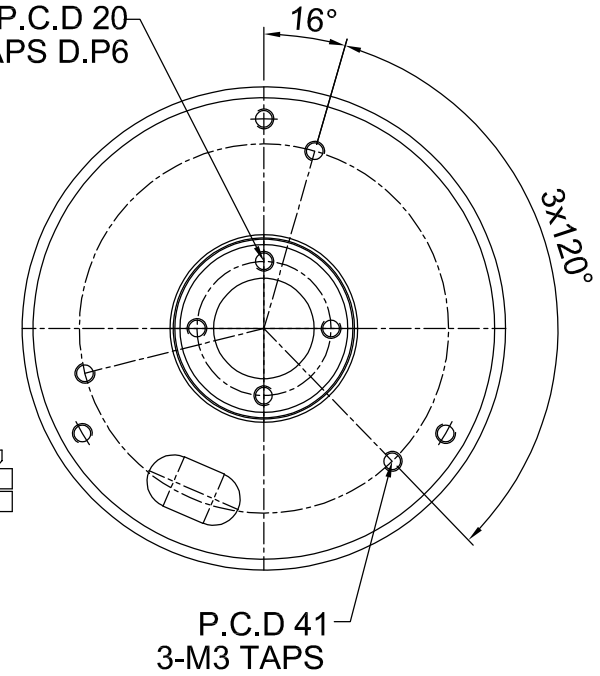
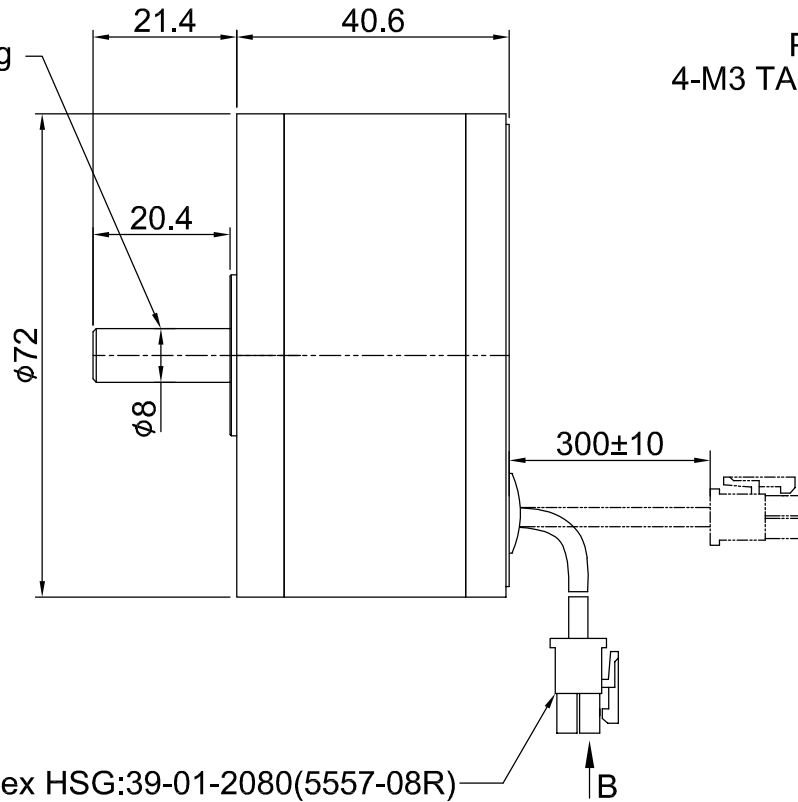
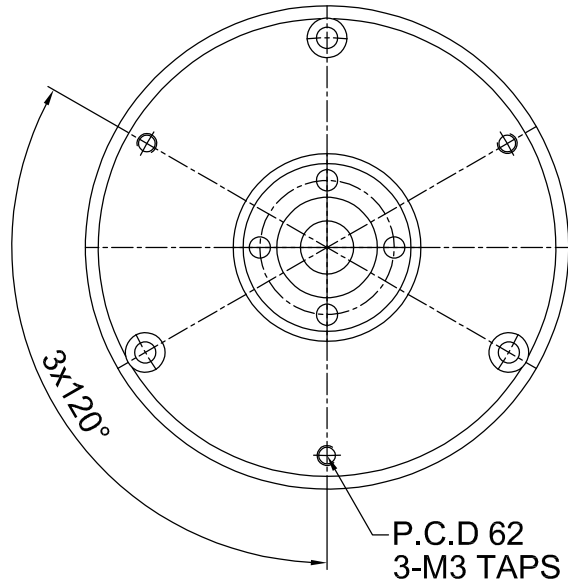

Molex HSG:39-01-2080(5557-08R)
PIN :39-00-0046(5556T2)

A Fig.1 Refer drawing
Model : Solid Shaft

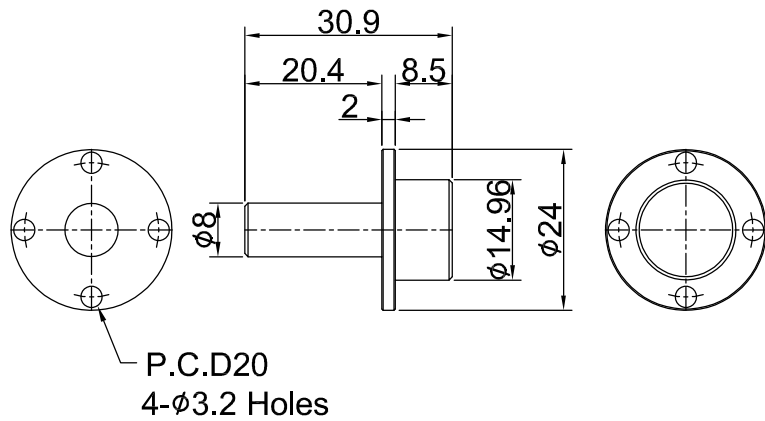

B Fig.2 Connecor

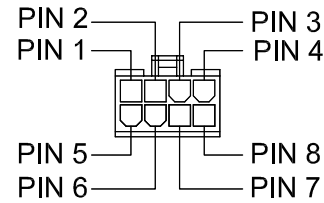

Table.1 Connector Interface (Motor)

Pin No.	COLOR	FUNCTION	LEAD WIRE
1	BLACK	GND	UL1061 AWG 26
2	BLUE	Motor W	UL 1061 AWG 22
3	GREEN	Motor V	
4	YELLOW	Motor U	UL 1061 AWG 26
5	RED	VCC	
6	BROWN	Hall C	UL 1061 AWG 26
7	GRAY	Hall B	
8	WHITE	Hall A	

REV.	DATE	DESCRIPTION	DRWN
MATERIAL	-	PLATING	-
SCALE	N/S	PAPER A4	QUANTITY -
DWG NO.	DSM-721-24V-A-M-AX		DIMENSION mm



SUBJECT
DSM-721S
(Solid Type)